

BIOSELECT



# PERFECT SEPARATION RESULT

## BÖRGER BIOSELECT

*The Börger Bioselect stands for efficient separation technology. Using a purely mechanical process, liquid parts are separated from solid parts in the medium.*

### OPERATING PRINCIPLE

The media to be separated find their way through the inlet opening **(1)** into the vessel-like Bioselect. The outer cylinder is separated from the auger **(3)** by a roundly sealed wire-wound screen **(2)** pipe. The auger has a frictional connection to the drive. On the discharge side, a counter bearing stabilizes the smooth run of the auger. This way, the longest possible service life can be achieved with extremely low wear. The imported liquid flows into the screen area next to the drive. The liquid flows through the wedge wire screen **(2)** into the outer vessel area. The liquid drains through the liquid outlet **(4)**.

The solid contents remain on the screen surface. They are conveyed into the press channel **(5)** by the rotating auger **(3)**. Powerful subsequent dewatering takes place in the press channel **(5)**. The rotating auger has a Multi Disc **(6)** (sealing disk), which can be shifted in axial direction, at the non-drive end. The adjusting unit **(7)** presses the Multi Disc against the auger and the compressed thick matter plug. When the thrust force of the plug is greater than the spring force of the Easy Shift unit **(7)**, a slot for discharging is created by axial movement. A scraper edge is used to loosen and expel the solids. axial movement. A scraper edge is used to loosen and expel the solids.

Model	Capacity:
Bioselect RC 25	Up to 110 gpm
Bioselect RC 40	Up to 176 gpm
Bioselect RC 75	Up to 330 gpm
Bioselect RC 150	Up to 660 gpm

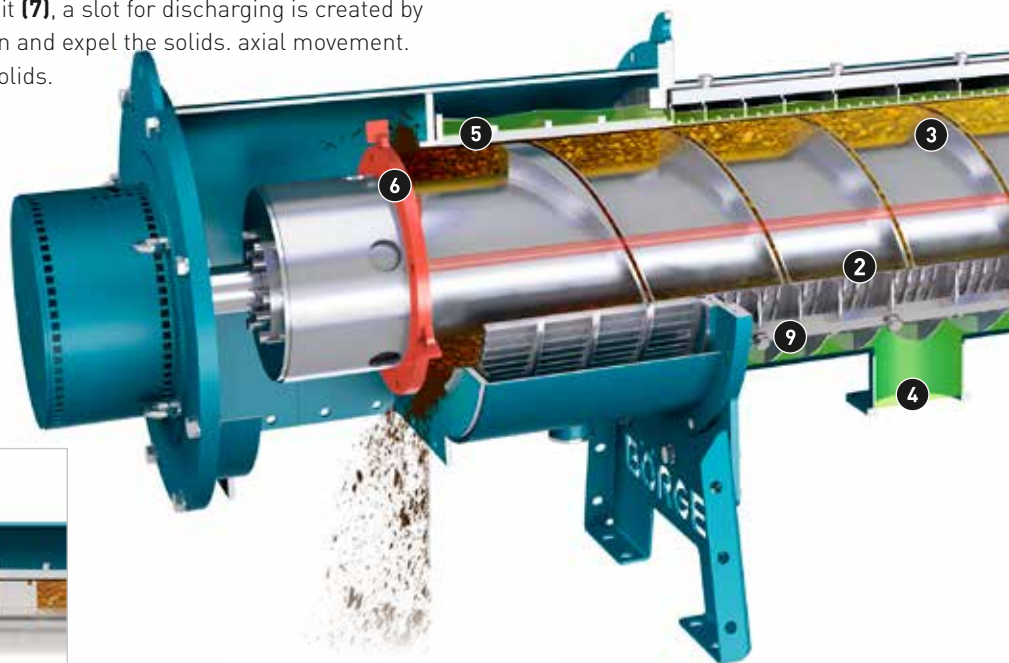

### MULTI DISC

Liquid penetration is impossible due to the Multi Disc technology **(6)**. The Multi Disc **(6)** seals the press channel **(5)** directly and until the required dry content of the thick matter plug is achieved. This is when the slot for discharging opens and the solid phase is loosened and expelled – **penetration-proof technology**.

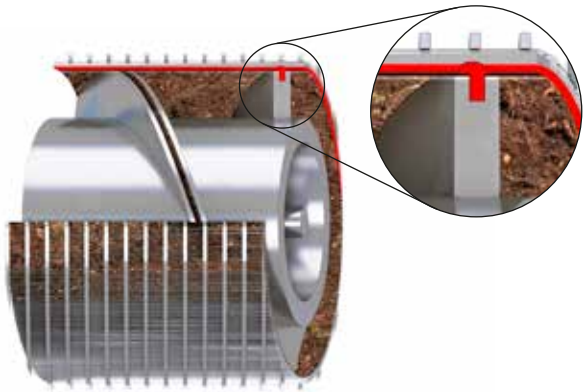

## AUGER WITH PROFILE GROOVE

Fibers are caught in the profile groove of the auger **(3)**. The fibers function as a sealing brush. Metallic rubbing between the auger and the wedge wire screen **(2)** is avoided by the brush. This unique technology increases the service life of the wedge wire screen **(2)** and auger many times over. In addition, the brushing surface cleans the wedge wire screen very thoroughly. Additional cleaning by the operator is not necessary.

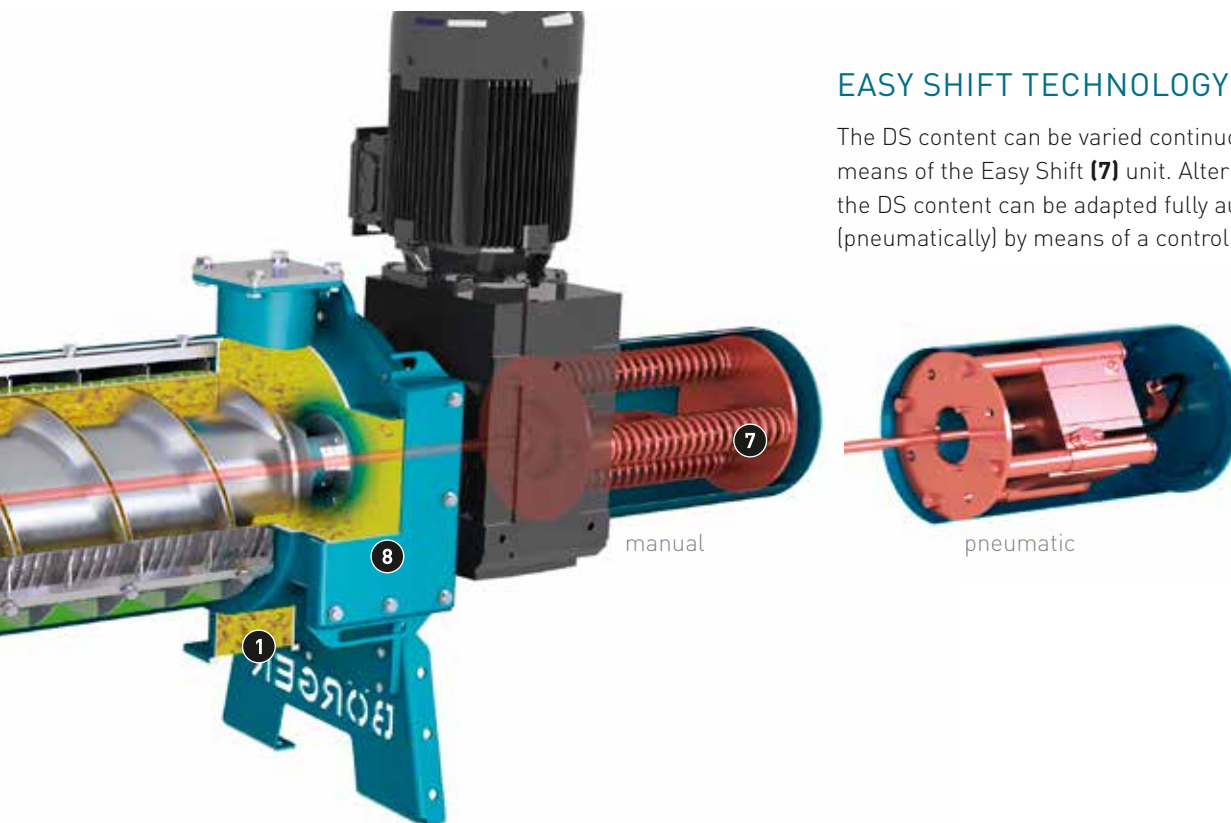

## EASY SHIFT TECHNOLOGY

The DS content can be varied continuously by means of the Easy Shift **(7)** unit. Alternatively, the DS content can be adapted fully automatically (pneumatically) by means of a control unit.

## DURABLE TWO-FILTER SYSTEM

The filter system of the Bioselect is divided into two areas. In drainage area 1, drainage takes place without pressure. Here, a wedge wire screen with a high screening capacity is used **(9)**. In drainage area 2 (press channel), high pressure is produced. In this area, a special wedge wire screen with 15 mm filter bars is used **(5)**.

The two-filter system ensures maximum efficiency and the longest possible service life.

## UNIQUE EASE OF MAINTENANCE

The Bioselect is maintained at the installation site without the need to remove piping and the drive system. The auger **(3)** can be removed from the drive shaft through the maintenance opening **(8)** after a few screws have been loosened. This way, the auger can be removed from the discharge side with minimum space requirements. The operator themselves can maintain the Bioselect. Easily and quickly.



## THE CONTROL TECHNOLOGY

Upon request, our in-house electrical engineering department produces and programs a control technology which is perfectly matched to your requirements.

- Ideal coordination of the operation of all components (e.g. feed pump, macerator, liquid phase pump, Bioselect)
- Perfect utilization of the Bioselect, even with changing composition of the medium being fed, by a control that ensures optimal loading (metered feeding); the results are a high energy efficiency and wear reduction
- Production data acquisition (operating hours, flow rate, etc.)
- Protection of the entire system (pressure monitoring, dry run protection, function monitoring, etc.)
- Integration e.g. to a biogas central computer via bus system (Profinet, Profi- or Modbus, etc.)
- External control by operator possible via mobile communication, WLAN, DSL (remote support by Börger is also possible)
- Simple coupling with a PV system, effective use of own electricity
- Further functions tailored to the customer and project are possible

+ Large capacities, low energy consumption

+ Solid phase infinitely variable up to a solid content of 38 %

+ No rubbing wear between the auger and screen, extremely long service life

+ No risk of penetration – the rotating Multi Disc is always leakproof due to its design

+ Four sizes with capacities of up to 150 m<sup>3</sup>/h for each unit

+ «Everything from a single source»  
– separator, pump, control unit and service



## CONNECTION OPTIONS

The Bioselect can be operated very easily by means of the control unit. The control unit coordinates the operation of the feed pump and Bioselect perfectly. This way, the separator is always operated at optimal capacity and achieves the best possible results.

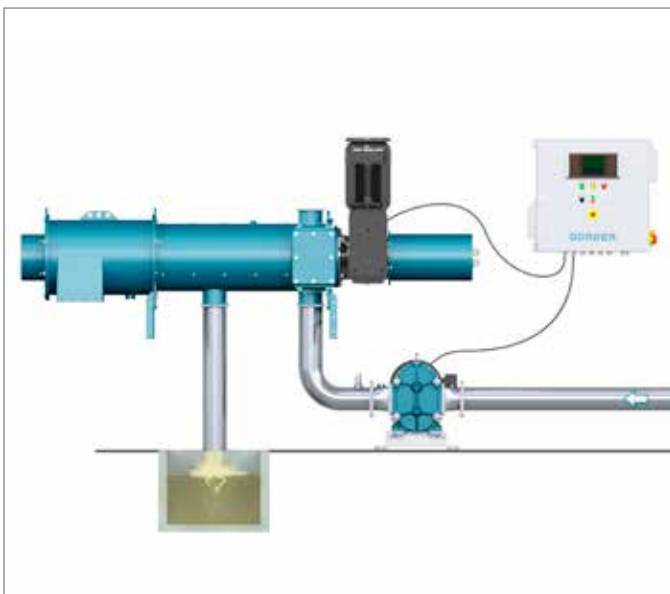

Free outlet of the liquid phase.



Alternatively, a liquid phase pump can convey the liquid phase to where it is used next. An intermediate container is not required.

# MOBILE OR STATIONARY CUSTOMIZED INSTALLATIONS

## INSTALLATION OPTIONS

The installation options of the Bioselect are as versatile as their requirements. Whether attached to a simple wall bracket, installed on a movable frame with an upstream macerator or as a mobile raised hydraulically version or with a conveyor belt – the application options of the Bioselect are unique.

### ON A WALL BRACKET



### ON A FRAME



### COMPACT DESIGN WITH MINIMUM SPACE REQUIREMENTS



### MOBILE & RAISED HYDRAULICALLY

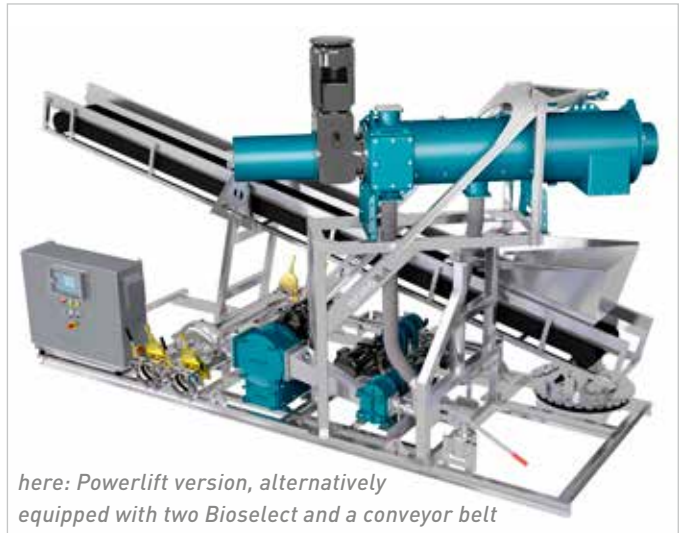

*here: Powerlift version, alternatively  
equipped with two Bioselect and a conveyor belt*



## BIOSELECT. EFFICIENT AND DURABLE.

Thanks to its patented technology, the sophisticated Bioselect is up to 25% more efficient than common separators – energy-saving and low-maintenance.

